

SUPER HIGH-DENSITY REALTIME DISASTER MITIGATION SYSTEM FOR CITY GAS SUPPLY, WITH ENHANCED USE OF GIS

Y. Shimizu^{a,*}, F. Yamazaki^b, R. Isoyama^c, T. Suzuki^d

^a Pipeline Department, Tokyo Gas Co., Ltd, JAPAN, yshimizu@tokyo-gas.co.jp

^b Dept of Urban Environment Systems, Faculty of Engineering, Chiba University, JAPAN, yamazaki@tu.chiba-u.ac.jp

^c Japan Engineering Consultants Co., Ltd, JAPAN, isoyama@jecc.co.jp

^d Department of Civil Engineering, Tokyo University, JAPAN, Suzuki@eng.toyo.ac.jp

KEY WORDS: Realtime Disaster Mitigation Damage Assessment, GIS, SUPREME, City Gas, SI Sensor

ABSTRACT:

To cope with earthquake related secondary disasters, the new real-time disaster mitigation system for a city gas network has been developed by Tokyo Gas Co. since 1998 for the purpose of realization of dense real-time seismic motion monitoring, quick gas supply shut-off, prompt emergency response and efficient restoration work. In 2001, Tokyo Gas successfully started the operation of SUPREME, which employs 3,800 new SI sensors and remote control devices at all the district regulator stations in its service area (3100km²). SUPREME can observe the status of 3,800 district regulators and shut them off remotely, if necessary. The remote shut-off using SUPREME can realize quick gas supply shut-off and effectively reduce gas leakage risk during earthquakes. The SUPREME can also conduct damage assessment for gas pipe with enhanced use of GIS. To estimate the distribution of SI values and liquefied depth more precisely, digital map, geological map, topographical map and borehole logging data of about 60,000 sites were collected and compiled. Site amplification factors for SI values were estimated at the boring points. Then, spatial distribution of the site amplification factor was estimated based on weighted average of the amplification factors of surrounding boring points and the geological / topographical maps, which is used to estimate the spatial variation of surface SI value from observed SI values by the new SI sensors. The predicted surface SI distribution of 50m x 50m mesh is utilized to estimate seismic damage to low-pressure gas pipeline. In case of liquefaction, a method to evaluate spatial distribution of liquefied depth and P_L was developed also. Based on the method, spatial distribution of liquefaction-induced damage to low-pressure gas pipeline will be estimated in realtime during an earthquake.

1. INTRODUCTION

Urban gas supply is one of the important sources of energy, which support many aspects of life. As compared with other energy sources, gas is more vulnerable to earthquake risk. Since it is flammable, a possible leakage due to damages in pipes and other facilities may lead to significant fires and, in the worst case, explosions. The conventional emergency measure to avoid gas-related hazards has been shutting-down of gas supply.

Table 1[1] reveals the detailed feature of damages related to gas supply networks during the Kobe earthquake in 1995. It was thus demonstrated that there is a need to initiate the emergency measures more quickly. Without knowing the situation of gas supply network, it was difficult to make a decision immediately after a quake whether the gas supply should be suspended or not. Consequently, efforts were initiated to develop a real-time system to mitigate earthquake-induced damages in gas supply networks which aimed collecting information quickly and, if necessary, carrying out emergency measures.

The Tokyo Gas understood the need of a real-time system in 1980's. The first version of such a system was named SIGNAL[2] for which the development efforts started in 1986 and its service started in June, 1994; seven months prior to the Kobe earthquake. Recently a new compact seismograph was developed. Being called "New SI Sensor,[3]" this device houses an electronic circuit which determines the SI value more precisely, detects the onset of liquefaction, and transmits the

whole time history of seismic acceleration to the head quarter. Consequently, a new safety system called SUPREME (SUPERdense REaltime Monitoring of Earthquake) was developed which makes use of 3,800 of new SI sensors. The present text is going to introduce the structure of this new system.

Table 1 Damage to gas supply network during Kobe earthquake

Number of leakage	106 in trunk pipes with medium pressure 26,459 in service pipes of low pressure, consisting of 5,190 under road pavement, 6,184 in connection to customer, and 15,085 in customers' pipe.
Time until shut-down	about 15 hours
Number of shut-down	859,000
Days until recovery	85 days

2. SEISMIC SAFETY MEASURE IN URBAN GAS INDUSTRY

The SUPREME does not function independently. It is always supported by the conventional safety measures. In this respect, it is very important to introduce here the basic structure of the seismic safety measure which has been practiced by the Tokyo Gas Company.

* Corresponding author. This is useful to know for communication with the appropriate person in cases with more than one author.

This company has a service area of 3,100 km² in and around Tokyo where there are 10 million customers (as of March 2004). Fig.1 illustrates the structure of the gas supply network in which pipelines are classified into for groups. "Regulators" in Fig.1 are the facilities to lower the gas pressure. 3800 district regulators reduce the pressure from the medium level to the lowest.

The basic philosophy is that gas facilities should maintain their serviceability without damage during strong earthquakes. Consequently, the trunk pipelines with high and medium pressures have received high standards of seismic safety.

In contrast to trunk pipes, those with lower gas pressure are prone to earthquake hazards. In particular, 21,000 damages were reported in small pipes during the Kobe earthquake. Although improvement of seismic resistance of those small pipes is desired, it is not practically possible to date due to the following reasons, such as the total length of pipeline is too enormous for any immediate action to be taken, and those pipes in the land of customers are customers' property which the gas company cannot control. Consequently, it is very likely that those pipelines will cause many leakage problems during a big earthquake. To still avoid significant problems induced by leakage, it seems reasonable to stop gas supply automatically by sensing the intensity of earthquake motion.

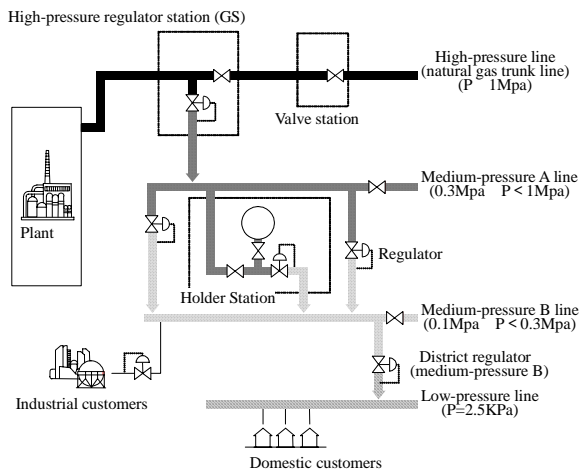

Fig.1 Schematic diagram of pipeline network of Tokyo Gas Company.

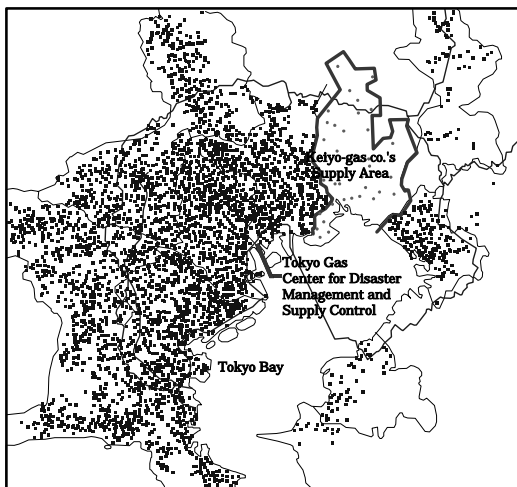

Fig.2 Locations of monitoring stations in SUPREME

The idea of safety as mentioned above is made real by the SI sensor. A district regulator which at normal time reduces the level of gas pressure from the medium one to the lowest. This

facility is equipped with an SI sensor that monitors the seismic spectrum intensity which was originally proposed by Housner[4] and takes a value similar to the maximum velocity of ground motion;

$$SI = \frac{1}{2.4} \int_{0.1}^{2.5} Sv(\text{damping}=20\%)dT \quad (1)$$

in which SV is the relative velocity response spectrum of the observed earthquake motion at a natural period of T . To date, a district regulator stops the gas supply if the monitored SI value exceeds 30 to 40 cm/sec to avoid secondary disasters caused by gas leaks. Here, it is the reason to set the SI value as 30 to 40 cm/sec that the damage of low pressure gas pipes and houses usually start to occur if SI values exceeds 30 cm/sec. The newly introduced SUPREME system will function based on these achievements so far made.

3. FEATURES OF SUPREME AND ITS UTILIZATION

3.1 New SI Sensors

Tokyo Gas has installed SI sensors in district regulators since 1986 to facilitate automatic shutoff in the event of an earthquake. The company is currently replacing these obsolescent SI sensors to New SI sensors, developed by Tokyo Gas, as shown in Figure 3. The new sensors are ultra-compact high-performance seismometers that have been developed with the micro-machining techniques that were not available when the original sensors were developed. The New SI sensors incorporate the following features and functions.

- Ultra-compact: Acceleration detection unit, CPU and RAM incorporated with the help of micro-machining techniques
- Low cost: 1/5 of the cost of a conventional seismometer
- High-precision SI calculation: Carries out real-time high-precision measurement of SI and maximum acceleration values
- Liquefaction detection: Uses the world's first real-time seismometer-based liquefaction monitoring technology
- Self-diagnostic: Carries out self-diagnostic and warns of malfunctions in acceleration pickups, electrical circuits, etc.
- Control: Closes shutoff valves, etc. on the basis of combined SI and maximum acceleration values
- Time-history memory: Records three-component acceleration time-histories

Tokyo Gas has been in the process of installing the new type of sensor in all its district regulators since fiscal 1997 and expects to have installed a total of 3,000 sensors by the spring of 2004.

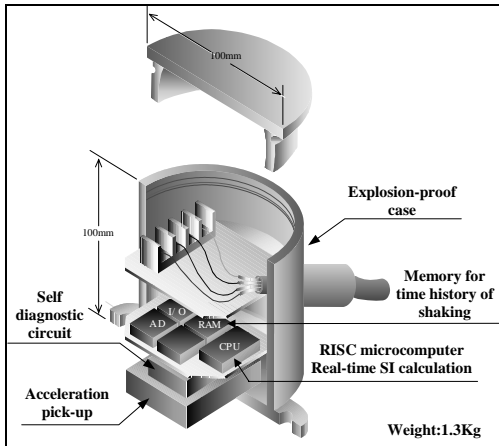

Fig. 3 Sketch of new SI sensor.

3.2 Structure of SUPREME System

The SUPREME system as shown in Fig.4 is characterized by the use of the New SI sensor. This sensor together with monitoring device for gas pressure, and shut-down action of gas valves are installed at all the 3,800 district regulator stations. Since the total service area is 3,100 km², there is, on average, one monitoring station per every 0.9 km². Moreover, there are 20 liquefaction sensors which monitor the subsurface pore water pressure and detect liquefaction directly [5]. Table.2 indicates the number of data sources in the system.

As of March, 2004, 3,000 district regulator stations have

Type of data	through wireless	through telephone network
SI and acceleration	332 including 300 district regulator stations	3,000 New SI sensors
Onset of liquefaction	20 liquefaction sensors and 300 New SI sensors	3,000 New SI sensors
Gas pressure, flow, and shut-down	300	all the 3,800 district regulator stations

received New SI sensors, while all the 3,800 stations will be equipped with the sensor until 2006. The communication between those sensors and the head quarter where the decision of shut-down is made by a computer relies on two kinds of channels. The one is a company-owned wireless and 332 stations are connected to this. The remaining 3,500 stations rely on the ordinary telephone network. Although the ordinary network is less reliable upon seismic emergency, the cost-performance analysis made this feasible. A special provision against telecommunication congestion is made by getting a special privilege from the telephone company. Accordingly, it is aimed that the control center at the head quarter can receive 80% of needed information within 20 minutes after a quake. This rate of response was facilitated by developing a new data-communication unit (called DCX).

Table 2 Number of data collected by SUPREME (as of March 2004).

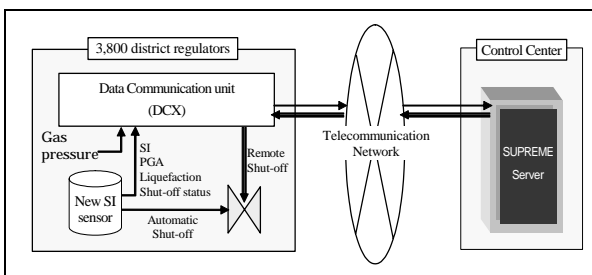

Fig.4 Illustration of SUPREME system.

3.3 SUPREME Utilization

Automated shut-off devices are now installed at all the district regulators for that purpose but it is not sufficient. Because of difference in site amplification, ground motion will vary at each regulator by regulator. Then, it will happen that some regulators are shut off but others are still working. Since low-pressure gas pipeline is densely networked and linked to neighboring regulators, gas supply will continue if there is working regulator nearby. In other words, gas leakage cannot be stopped. In such a case, company staff will be seconded to the site to shut off working regulators manually. However, during big earthquake because of congestion in traffics and road damages, such work is quite difficult and time consuming.

Countermeasures for it is "Remote shut-off". Here, conventional remote control system which is commonly used for high-pressure pipeline system, uses company's radio communication or dedicated line with redundancy to keep high quality and security. But this system is not suitable for 3,800 district regulator stations in SUPREME, by reason of its cost. Public line has been already installed at all stations but it is not appropriate for remote shut-off in terms of security, because anyone who knows the phone number can easily shut off the regulator. Then, the remote shut-off unit has been developed to achieve high reliability and security for remote control of regulators even if public lines are used to solve the cost problem.

The remote shut-off unit is installed at each regulator stations, as shown in Fig.5 to accept the remote shut-off command from SUPREME Host only for a short time (6 hours) just after earthquake, to prevent hacker's attack in an ordinary time. It has the so-called "GATE", which is normally closed but opens only when ground shaking is measured by both New SI sensor and mechanical starter to accept the command through the DCX using public lines. The opening trigger is set as 10 cm/s for New SI sensor and 50 cm/s² for mechanical starter, as shown in Fig.5. Consequently, the installation cost of remote shut-off units will be 1/40 of the one of conventional system.

Immediately after an earthquake has occurred, SUPREME combines SI values, maximum acceleration values, and liquefaction alerts transmitted from the super high-density New SI sensors with GIS system data such as gas pipeline network, topographical and soil data, and uses it to make an extremely precise assessment of the pipe damage incurred. The damage is also ascertained by raw data collected from sensors such as the pressure gauges installed in district regulators. Furthermore, by both automatic and tele-control function of New SI sensor for the shut-off valves at district regulators, quick emergency response can be realized.

At normal time, the analysis of site amplification characteristics is carried out using time-history data from the New SI sensors (Fig.6). The results are incorporated into the ground zoning plan.

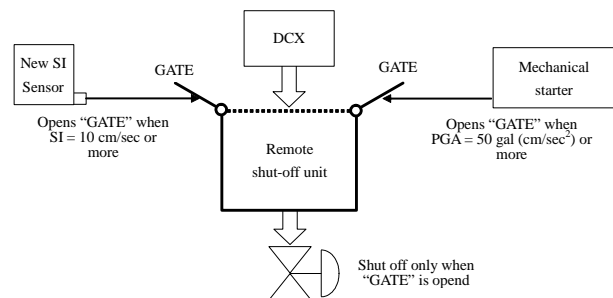

Fig.5 Mechanism of remote shut-off unit

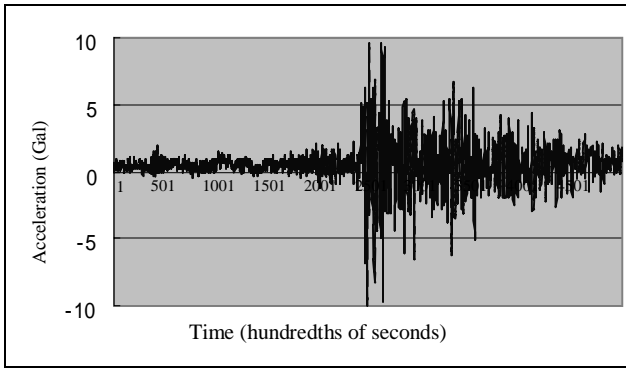

Fig.6 Seismic data, 1998/1/14 (Konan, Minato ward)

4. PREPARATION OF SITE AMPLIFICATION DATABASE

For more precise damage assessment by SUPREME, the database of site amplification factors was prepared. We analyzed the relationship between bore-hole logging data and site amplification factors using the seismic time-histories obtained by K-NET [6], and 60,000 points bore-hole data. We estimated the site amplification on each boring point and interpolated to prepare surface site amplification database in a 50m mesh.

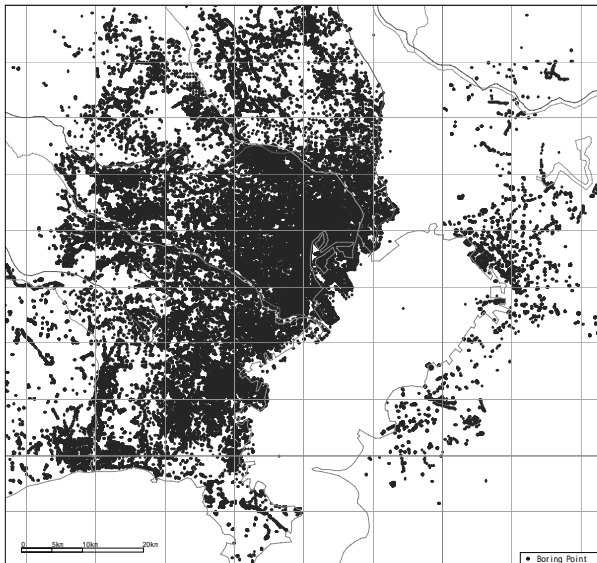

Fig. 7 Sites of bore holes employed in SUPREME.

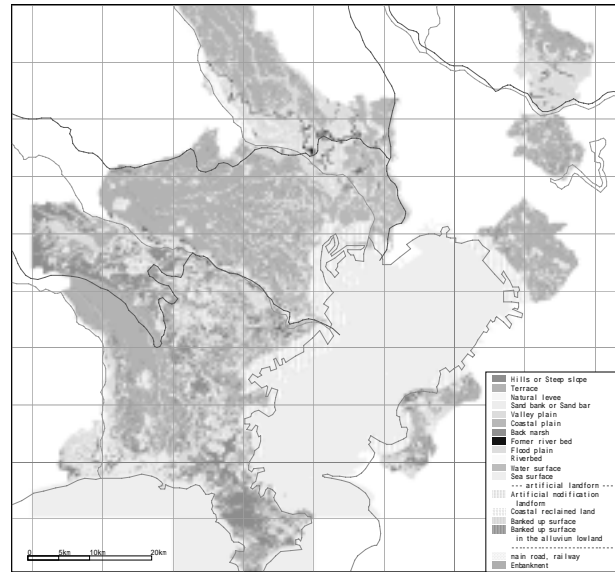

Fig.8 Surface geology map employed in SUPREME.

4.1 Preparation of Database on GIS

The SUPREME system consists of 3,800 monitoring stations. Accordingly, there is only one station in every 0.9 km² of the service area. It is apparently difficult to infer the damage situation of the area out of data obtained at a single station. To overcome this problem and conduct an interpolation among stations in a reasonable way, a geographic information system (GIS) was introduced.

The present GIS has borehole data from 60,000 sites. Prepared partially by the Tokyo Gas Company and partially supplied by many municipalities in the service area, the digitized borehole information consists of the location, depth, types of soil, SPT blow counts, surface elevation, and the elevation of ground water table. This enabled microzonation of the area based on individual borehole data (Fig. 7). Note that the seismic amplification is strongly affected by the thickness and soil properties of surface soil deposits. Another important information in the system is that of surface geology (Fig. 8). As is well known, the types of surface quaternary geology such as alluvial plane, abandoned river channels, natural levee, and others affect the liquefaction potential [7].

4.2 Relationship between Average S-wave Velocity and the SI Values Site Amplification Based on K-NET Data

To study the relationship between bore-hole logging data, geographical data and site amplification characteristics, we analyzed the relationship between the amplitude of SI values based on data obtained from K-NET and the average velocity of an S-waveform calculated from PS logging data. Our analysis showed that the following equation using travel time averages down to a depth of 20m[8] is the best way to estimate site amplification.

$$\text{Log}_{10}\lambda = -0.785 \text{log}_{10} (\text{AVS}20) + 2.18 \quad (2)$$

where λ is the SI value amplification, and AVS20 is the average S-wave velocity (m/s) based on travel times down to depths of 20m. We defined the standard base rock as an average S-wave velocity of 600 (m/s). The following travel time-based equation was used to calculate the average.

$$\text{AVS}20 = \frac{\sum_j h_j}{\sum_j (h_j / V_{s_j})} \quad (3)$$

Where V_{s_j} is the S-wave velocity (m/s) of layer j , h_j is the thickness (m) of layer j , Σ_j is the aggregate of all layers j down to a depth of 20m. Fig. 9 shows Eq. (2) and the relationship between SI value amplification based on observation records and average S-wave velocity based on travel times down to a depth of 20m at strong-motion observatory in Yokohama. The equation itself has been devised on the basis of K-NET records but even when using the Yokohama records, a correlation coefficient was as large as 0.65.

4.3 Estimation of Average S-wave Velocity Using Borehole Data

The following equations were used to estimate average S-wave velocities from SPT-N values and soil type[9], using borehole data obtained from about 60,000 points around the service area.

$$Vs_j = 100 N_j^{1/3} \text{ (clayey soil, } 1 \leq N_j \leq 25) \quad (4)$$

$$Vs_j = 80 N_j^{1/3} \text{ (sandy soil, } 1 \leq N_j \leq 50) \quad (5)$$

Where N_j is the N value at each depth j , and V_{s_j} is the estimated S-wave velocity (m/s). Fig. 10 compares the actual average S-wave velocities obtained from PS logging at 150 strong motion observatory of Yokohama

with average S-wave velocities estimated on the basis of N values and soil types. Both data showed good fit (correlation coefficient of 0.87).

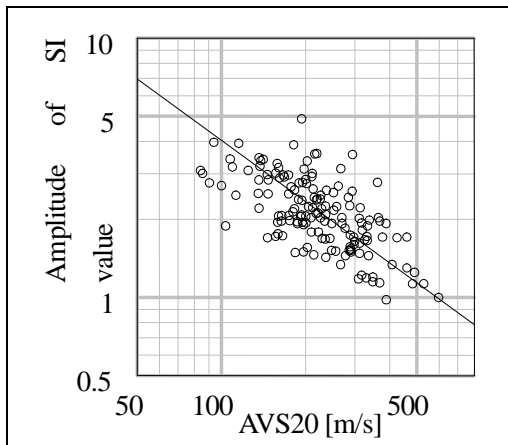

Fig. 9 Relationship between SI amplitude and AVS

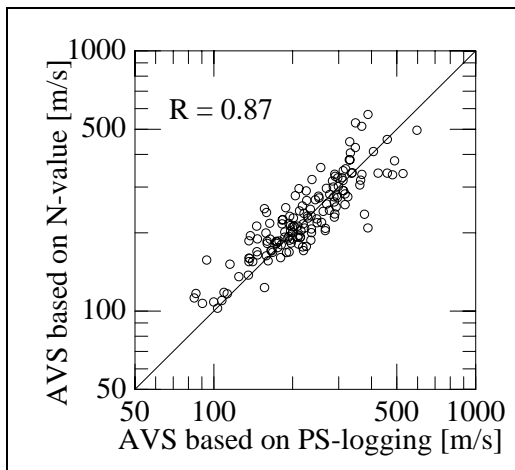

Fig. 10 Relationship between AVS based on PS logging and AVS estimated

4.4 Method for the Surface Interpolation of SI Value Amplitudes

As mentioned above, we obtained amplification factor at each boring point using Eqs. (3), (4) and (5). Using interpolation method, we estimate continuous distribution of SI value amplification. We used the following equation for the method.

$$y = \frac{\sum_i ((1/r_i^2) \cdot y_i) / \sum_j (1/r_j^2)} \quad (6)$$

where y is an estimated value, y_i is the value obtained at boring point i , r_i is the distance (m) between point to be estimated and boring point i , and Σ_i is the aggregate for boring points i used in the interpolation calculation. In this case, we have substituted y_i for $\log_{10}\lambda$ of the SI value amplification of each boring point found using Eq. (2). In the present calculation, we have categorized two broadly-defined topographical groups, high ground and low ground, and interpolated separately for the two groups. The calculations have been carried out on a 50m mesh basis but to ensure that valley areas are not overlooked, if a single mesh is deemed to be a valley on a 25m mesh basis, then it is also treated as a valley on the 50m mesh basis, thereby somewhat exaggerating the valley feature. Fig. 11 shows the two topographical groups in the service area. We also used the nearest five points of the same geological feature for interpolation calculation. The interpolation calculation results of SI amplification for the two whole of the Tokyo Gas service area are shown in Fig.12.

Finally, Fig. 13 was obtained from a simulation in which an earthquake of magnitude=7.0 occurs to the west of Tokyo and the whole service area is shaken.

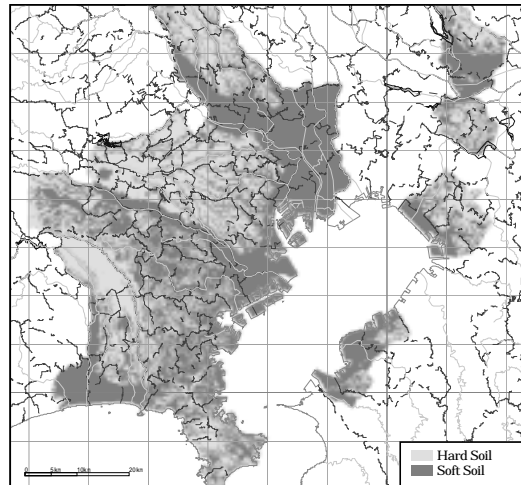

Fig. 11 Classified simplified surface geology in Tokyo and surrounding area.

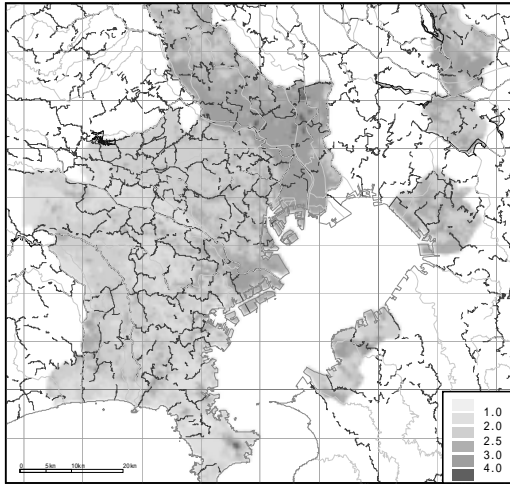

Fig. 12 SI amplification obtained by proposed interpolation method.

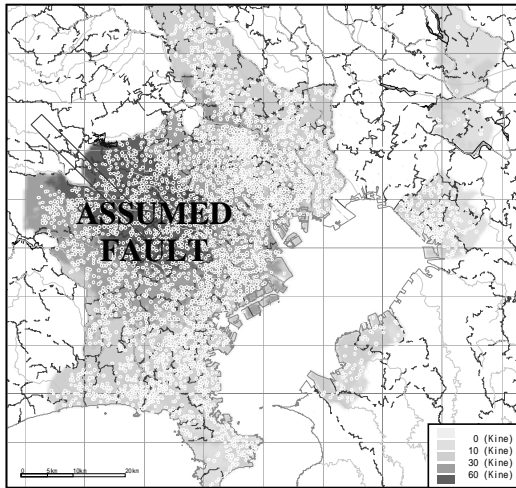

Fig. 13 Simulation of SI values in service area.

5. PRECISE DAMAGE ASSESSMENT

The final decision has to be made whether or not the low-pressure gas supply in the concerned block is interrupted by closing regulator valves. To make this decision making, the precise damage assessment by SUPREME, based on SI distribution data and pipe database of GIS, can be used. Past earthquake experiences gave a relationship between SI and the number of pipe damages. For example, the rate of damage to embedded screw-joint steel pipe is assessed by the following formula;

For alluvial plane;

$$R / R_0 = 1.00 \times \{2.35 - 1.35 \cos(\pi H / 10)\} \times \phi(SI) \quad (7)$$

For cuts and fills;

$$R / R_0 = 1.65 \times \{2.35 - 1.35 \cos(\pi H / 10)\} \times \phi(SI) \quad (8)$$

$$\phi(SI) = [\log(SI) - 4.305] / 0.509 \quad (9)$$

in which R is the number of damage per 1km length of pipeline, and R_0 is the control damage rate being equal to 2.36/km, while H accounts for thickness of liquefied soil. Moreover, ϕ is a

function varying with SI at surface. With such a strong earthquake as the one in Kobe in mind, the pipeline damage records in Kobe area was analyzed to obtain such parameters. Fig.14 illustrates examples of damage rate assessment for cut-and-fill areas and alluvial planes.

Thus, the damage extent can be assessed by SI values. Then, the real decision making on shut-down of gas supply will be conducted based on this information.

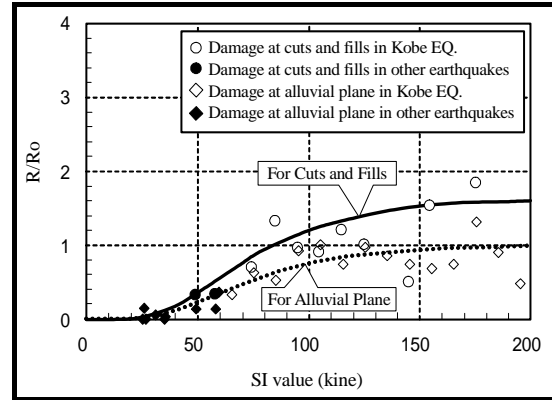

Fig.14 Assessed damage rate for screw-joint steel pipes

6. CONCLUSION

This completes our introduction of Tokyo Gas's new real-time disaster mitigation system "SUPREME" utilizing New SI sensors. Tokyo Gas's wealth of soil and topographical data was also used to study a method of preparing database of surface site amplification using GIS. From here on, we will be looking to utilize case studies to obtain more precise site amplification characteristics, to increase the efficiency of real-time damage assessment and to expand the use of SUPREME.

The development of the system was significantly promoted by the discussion conducted at the Association for Development of Earthquake Prediction with Dr. T. Katayama, Mr. J.Ikeda. The authors deeply appreciate those assistance and corporations supplied by the governments, institutes, and individuals.

7. REFERENCES

- Agency of Natural Resources and Energy (1996): Gas Industry Earthquake Countermeasures Study Report, pp7-11. (in Japanese)
- Yamazaki, F., Katayama, T., Noda, S., Yoshikawa, Y., and Ohtani, Y. (1995) Development of large-scale city-gas network alert system based on monitored earthquake ground motion, Proc. JSCE, 525/1-33, pp.331-340. (in Japanese)
- Koganemaru, K., Shimizu, Y., Yanada, T., Furukawa, H. and TAKUBO, K. (1999), "Development of New SI sensor", *Proceeding of the 6th Japan/United States Workshop on Urban Earthquake Hazard Reduction, J-1-8*.
- Housner, G.W. (1961): Vibration of structures induced by seismic waves Part I. Earthquakes, C.M.Harris and C.E.Crede (Eds.), *Shock and Vibration Handbook*, McGraw-Hill, pp. 50-1-50-32.
- Shimizu, Y., Yasuda, S., Morimoto, I. and Orense, R.P.(2002) Development of sensor for monitoring seismic liquefaction, *Soils and Foundations*, Vol.42, No.1, pp.35-52
- Kinoshita S. Kyoshin Net (K-Net). *Seismological Research Letters*, 1998; 69(4): 309-332
- Wakamatsu,K. (1991) *Maps for Historic Liquefaction Sites in Japan*, Tokai University Press (in Japanese).
- Tamura, I., F. Yamazaki, K.T. Shabestari: "Estimation of

ground amplitudes based on average S-wave velocities calculated using K-NET earthquake records", Proceedings of the 55th Annual Technology Presentation, 2000 (in Japanese)

9. Japan Road Association: Design Specifications of Road Bridges; Part V: Seismic Design, (and associated Explanation), 1996 (in Japanese)